



# EPS (ISO 26623-1) Werkzeugaufnahmen

Toolholders

Porte-outils

Takım Tutucular

INHALTSVERZEICHNIS / INDEX	Seite / Page
<b>Spannfutter für Spannzangen - Collet chucks</b> Mandrin à pinces - Pens başlığı	4.02 - 4.03
<b>Ausrichtbares Werkzeugspannfutter - Adjustable tool holder</b> Tige de réglage - Hassas ayarlanabilir pens tutucu	4.03
<b>Kraftspannfutter - Milling chuck</b> Mandrin de fraisage - Bilyalı pens tutucu	4.04
<b>Fräseraufnahmen - End mill holder</b> Porte-fraises - Veldon tutucu	4.05 - 4.08
<b>Zwischenhülsen - Morse taper adapter</b> Douilles intermédiaires - Mors adaptörü	4.08
<b>Kombi-Aufsteckfräserdorne - Combi shell mill holder</b> Porte-fraises à double usage pour fraises - Kombine malafa	4.09
<b>Quernut-Aufsteckdorne - Shell mill holder</b> Porte-fraises à surfacer - Alın kamalı malafa	4.10
<b>Aufschraubfräser - Milling cutter arbors</b> Axess coupeur fraisage - Vidalı takım tutucu	4.11
<b>Bohrerhalter E1 - Boring holder E1</b> Porte forêt E1 - Takma uçlu drill tutucu E1	4.12
<b>Bohrerhalter E2 - Boring bar holder E2</b> Porte-outil E2 - İç çap tornalama kater tutucu E2	4.12
<b>NC Bohrfutter - NC drill chuck</b> Mandrin de perçage - NC mandren malafası	4.13
<b>Gewindeschneidfutter - Quick change tapping chuck</b> Appareil à tarauder - Kılavuz çekme başlığı	4.14
<b>Rohlinge - Blanks</b> Barre d'alésage - Özel takım yapma amaçlı yarı mamul	4.15
<b>Kontrolldorne - Test arbors</b> Mandrin de contrôle - Kontrol mastarı	4.16
<b>Einrichtehalter - Setting-holder</b> Porte outil de réglage - Pozisyon kontrol mastarı	4.16
<b>Schrumpffutter - Shrink chuck</b> Mandrin de frettage - Isıtmalı takım tutucular	4.17 - 4.19
<b>Hydro Dehnspannfutter - Hydraulic expansions chuck</b> Mandrin expansibles hydrauliques - Hidrolik takım tutucular	4.20
<b>Werkzeughalter - Toolholder</b> Porte-outil - Kater tutucu	4.21 - 4.23



EPS  
(ISO 26623-1)

**Mit EROGLU erhalten Sie auch Semi-Standard – in der gleichen Qualität!**

**With EROGLU you receive semi-standard, too – within the same quality!**

**Avec EROGLU vous recevez aussi semi-standard – avec la même qualité!**

**Özel ürün seçenekleri ile EROĞLU kalitesi hep sizinle...**

## . G2.5 x ...

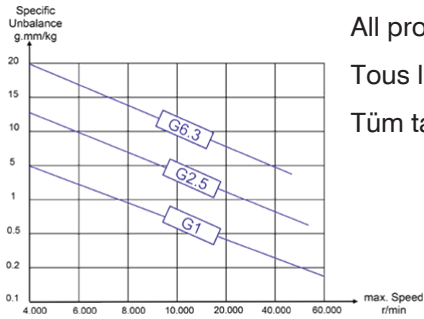

Alle Artikel können mit dem angegebenen Maximalwert feingewuchtet werden.

All products can be produced in the specified maximum balance value.

Tous les articles peuvent être spécifiés avec le maximum de précision équilibrée.

Tüm takım tutucular belirlenen max. balans değerlerinde üretilebilir.



## Toolholders

## Porte-outils

## Konik Şaft Ölçüleri

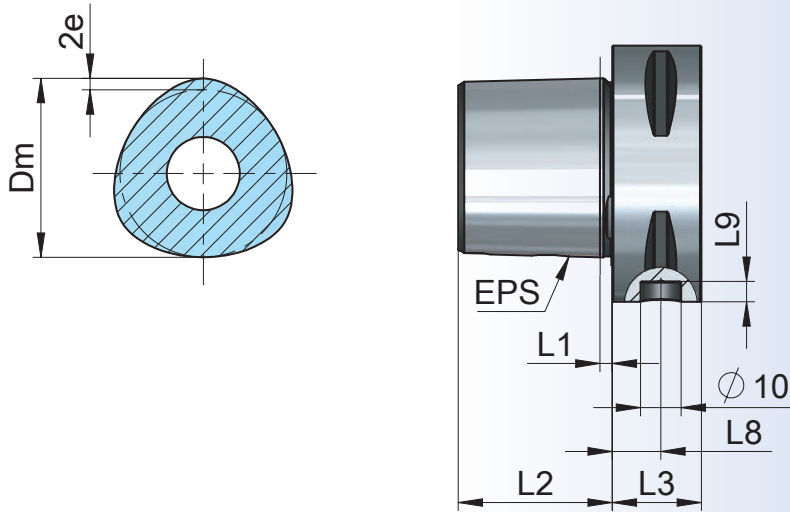

EPS	Dm	e	L1	L2	L3	L8	L9
32	22	0,70	2,5	19	15	9	5,4
40	28	0,90	2,5	24	20	12	5,2
50	35	1,12	3	30	20	12	5,1
63	44	1,40	3	38	22	12	5,0
80	55	2,00	3	48	30	12	4,9
100	72	2,80	3	60	36	16	4,9

**Werkstoff** : Legierter Einsatzstahl mit einer Zugfestigkeit im Kern von mindestens 950 N/mm<sup>2</sup>

**Ausführung** : Einsatzgehärtet HRC 58 ± 2 Härtetiefe 0,6 mm + 0,2 mm, brüniert

**Genauigkeit** : Polygonform und Kegelwinkel nach ISO 26623-1  
Oberflächenrauigkeit des Kegels Ra 0,3

**Material** : Case hardened steel, tensile strength in the core min. 950 N/mm<sup>2</sup>

**Execution** : Casehardened HRC 58 ± 2 Depth of case 0,6 mm + 0,2 mm, black-finish

**Accuracy** : Polygon form and cone angle according to ISO 26623-1  
Surface roughness of cone max. Ra 0,3

**Matière** : Châssis d'allié en acier de cémentation. Résistance à la traction dans le noyau de min 950 N/mm<sup>2</sup>

**Exécution** : Cémenté HRC 58 ± 2 Epaisseur de cémentation 0,6 mm + 0,2 mm, bruni

**Précision** : Formé de polygone et qualité de finition pour l'angle du cône suivant ISO 26623-1  
Rugosité en surface du cône Ra 0,3

**Malzeme** : Alaşımlı semente çeliği çekme mukavemeti min. 950 N/mm<sup>2</sup>

**Teknik özelliği**: Sertlik HRC 58 ± 2 sertlik derinliği 0,6 mm + 0,2 mm, karartılmış

**Hassasiyeti** : Konik açı tolerans kalitesi ISO 26623-1 normuna göre  
Konik yüzey kalitesi Ra 0,3



## Spannfutter ER

EPS

### Collet chucks ER

### Mandrin à pinces ER

### Pens başlığı ER



Bestell-Nr. Order Nr. Reference Sipariş Nr.	EPS	Spannbereich Capacity Capacité Kapasite	A	D	D1	L1	L2	Kg	Euro
EP3.02.10.45	EPS 32	ER16 (1-10)	45	28	-	-	32	0,19	
EP4.02.10.70	EPS 40	ER16 (1-10)	70	28	-	-	32	0,41	
EP4.02.16.52	EPS 40	ER25 (2-16)	52	42	-	-	42	0,38	
EP4.02.20.54	EPS 40	ER32 (2-20)	54	50	-	-	48	0,42	
EP5.02.10.55	EPS 50	ER16 (1-10)	55	28	-	-	32	0,52	
EP5.02.10.100	EPS 50	ER16 (1-10)	100	28	-	-	32	0,71	
EP5.02.16.55	EPS 50	ER25 (2-16)	55	42	-	-	42	0,60	
EP5.02.16.100	EPS 50	ER25 (2-16)	100	42	-	-	42	1,03	
EP5.02.20.77	EPS 50	ER32 (2-20)	77	50	-	-	48	0,93	
EP5.02.20.100	EPS 50	ER32 (2-20)	100	50	-	-	48	1,25	
EP6.02.10.60	EPS 63	ER16 (1-10)	60	28	-	-	32	0,87	
EP6.02.10.100	EPS 63	ER16 (1-10)	100	28	-	-	32	1,03	
EP6.02.10.130	EPS 63	ER16 (1-10)	130	28	-	-	32	1,15	
EP6.02.16.60	EPS 63	ER25 (2-16)	60	42	-	-	42	0,95	
EP6.02.16.100	EPS 63	ER25 (2-16)	100	42	-	-	42	1,34	
EP6.02.16.130	EPS 63	ER25 (2-16)	130	42	-	-	42	1,65	
EP6.02.16.160	EPS 63	ER25 (2-16)	160	42	45,5	100	42	1,98	
EP6.02.20.60	EPS 63	ER32 (2-20)	60	50	-	-	48	1,00	
EP6.02.20.100	EPS 63	ER32 (2-20)	100	50	-	-	48	1,56	
EP6.02.20.130	EPS 63	ER32 (2-20)	130	50	-	-	48	1,99	
EP6.02.20.160	EPS 63	ER32 (2-20)	160	50	54	101	48	2,47	
EP6.02.26.65	EPS 63	ER40 (3-26)	65	63	-	-	55	1,21	
EP6.02.26.100	EPS 63	ER40 (3-26)	100	63	-	-	55	2,01	
EP6.02.26.130	EPS 63	ER40 (3-26)	130	63	-	-	55	2,71	
EP8.02.20.70	EPS 80	ER32 (2-20)	70	50	-	-	48	1,98	
EP8.02.20.160	EPS 80	ER32 (2-20)	160	50	53	101	48	3,30	
EP8.02.26.70	EPS 80	ER40 (3-26)	70	63	-	-	55	2,09	
EP8.02.26.160	EPS 80	ER40 (3-26)	160	63	65,5	103	55	4,23	

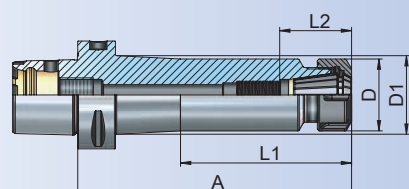

ER 16

### Zubehör / Accessories / Accessoires / Yedekler



Spannzangen System ER  
Collets System ER  
Pinces de serrage System ER  
Pens ER



Spannmutter ER  
Clamping nuts ER  
Écrou de serrage ER  
Pens kapağı ER



Spannschlüssel für ER  
Wrench ER  
Clé de serrage ER  
Anahtar ER



## Spannfutter ER Mini

EPS



### Collet chucks ER Mini

### Mandrin à pinces ER Mini

### Pens başlığı ER Mini

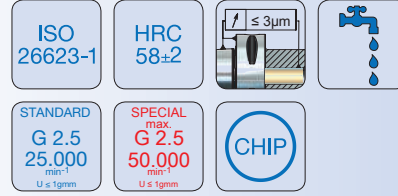

Bestell-Nr. Order Nr. Reference Sipariş Nr.	EPS	Spannbereich Capacity Capacité Kapasite	A	D	L2	Kg	Euro
EP5.02.10.100.M	EPS 50	ER16 (1-10)	100	22	32	0,58	
EP6.02.10.100.M	EPS 63	ER16 (1-10)	100	22	32	0,91	
EP6.02.10.130.M	EPS 63	ER16 (1-10)	130	22	32	1,00	

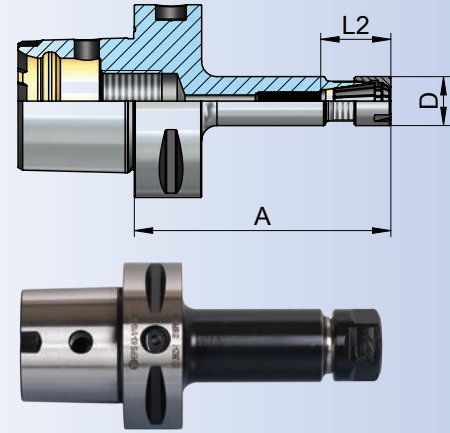

### Zubehör / Accessories / Accessoires / Yedekler

 DIN ISO 15488 Spannzangen System ER Collets System ER Pincés de serrage System ER Pens ER 10.11 - 10.18	 Spannmutter Mini Nut Mini Écrou mini Mini kapak 10.24	 Rollenschlüssel für Spannmutter Roller Bearing Wrenches Cles à rouleaux Bilyalı Kapak Sıkma Anahtar 10.47	 Spannschlüssel Wrench Clé de serrage Anahtar ER 10.48	 11.01
--	---	---	---	---

## Ausrichtbares Werkzeugspannfutter, radial und axial einstellbar

EPS

### Adjustable toolholder, adjustable radial and axial

### Mandrin à tige de réglage, réglage radial et axial

### Hassas ayarlanabilir pens tutucular, eksenel ve radyal yönde

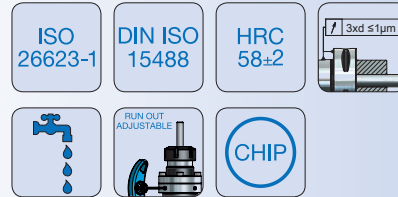

Bestell-Nr. Order Nr. Reference Sipariş Nr.	EPS	Spannbereich Capacity Capacité Kapasite	D	A	L1	L2	D1	M	M1	Kg	Euro
EP5.02.20.117.ARF-P	EPS 50	ER32 (2-20)	50	117	47	48	68	M6	M6	1,90	
EP6.02.20.117.ARF-P	EPS 63	ER32 (2-20)	50	117	47	48	68	M6	M6	2,30	

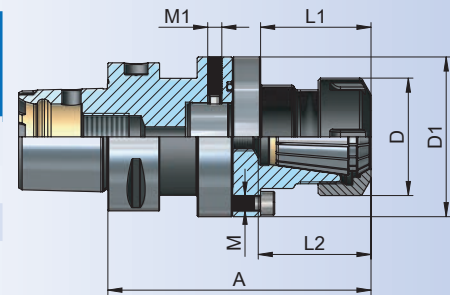

### Zubehör / Accessories / Accessoires / Yedekler

 DIN ISO 15488 Spannzangen System ER Collets System ER Pincés de serrage System ER Pens ER 10.11 - 10.18	 DIN ISO 15488 Spannmutter ER Clamping nuts ER Écrou de serrage ER Pens kapağı ER 10.25-10.26	 DIN 912 Anzugschraube Bolt Trette Civata 10.39	 DIN 915 Einstellschraube Adjusting screw Vis de réglage Ayar civatası 10.39	 Spannschlüssel für ER Wrench ER Clé de serrage ER Anahtar ER 10.48	 11.04
---	--	--	---	---	--



## Präzisionskraftspannfutter

EPS

Precision milling chuck

Mandrin de fraisage de précision

Bilyalı pens tutucu

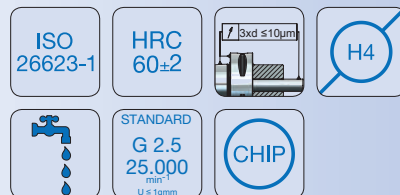

Bestell-Nr. Order Nr. Reference Sipariş Nr.	EPS	Spannbereich Capacity Capacité Kapasite	d	A	D	L2	Kg	Euro
EP5.03.20.100.N	EPS 50	EKS 20 (6-20)	20	100	48	80	1,27	
EP5.03.32.110.N	EPS 50	EKS 32 (6-32)	32	110	68	80	2,13	
EP6.03.20.100.N	EPS 63	EKS 20 (6-20)	20	100	48	80	1,61	
EP6.03.32.110.N	EPS 63	EKS 32 (6-32)	32	110	68	80	2,50	
EP8.03.20.100.N	EPS 80	EKS 20 (6-20)	20	100	48	80	2,46	
EP8.03.32.110.N	EPS 80	EKS 32 (6-32)	32	110	68	80	3,19	

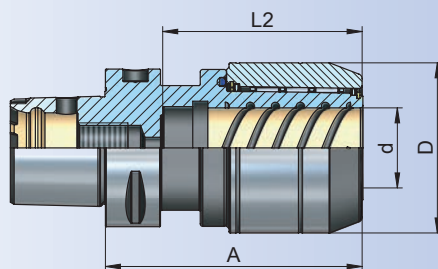

### Zubehör / Accessories / Accessoires / Yedekler



Spannzangen  
Collets  
Pincés de serrage  
Pens

10.19



Rollenschlüssel für Spannmutter  
Roller Bearing Wrenches  
Cles à rouleaux  
Bilyalı Kapak Sıkma Anahtar

10.47



11.02





End mill holder

Porte-fraises

Veldon tutucu

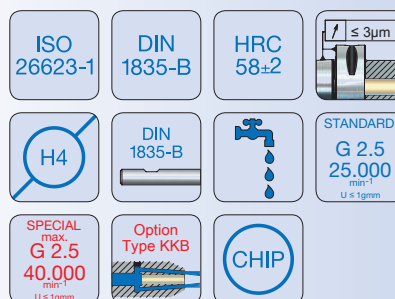

Bestell-Nr. Order Nr. Reference Sipariş Nr.	EPS	d	A	D	L2	Kg	Euro
EP3.04.06.46	EPS 32	6	46	25	36	0,21	
EP3.04.08.46	EPS 32	8	46	28	40	0,24	
EP3.04.10.50	EPS 32	10	50	35	44	0,33	
EP3.04.12.55	EPS 32	12	55	42	51	0,46	

EP4.04.06.50	EPS 40	6	50	25	36	0,34	
EP4.04.08.50	EPS 40	8	50	28	40	0,37	
EP4.04.10.51	EPS 40	10	51	35	44	0,44	
EP4.04.12.56	EPS 40	12	56	42	51	0,56	
EP4.04.14.55	EPS 40	14	55	44	51	0,56	
EP4.04.16.55	EPS 40	16	55	48	54	0,61	

EP5.04.06.50	EPS 50	6	50	25	36	0,51	
EP5.04.08.50	EPS 50	8	50	28	40	0,54	
EP5.04.10.55	EPS 50	10	55	35	44	0,64	
EP5.04.12.60	EPS 50	12	60	42	51	0,78	
EP5.04.14.60	EPS 50	14	60	44	51	0,80	
EP5.04.16.60	EPS 50	16	60	48	54	0,86	
EP5.04.18.60	EPS 50	18	60	50	54	0,89	
EP5.04.20.60	EPS 50	20	60	52	56	0,90	
EP5.04.25.80	EPS 50	25	80	63	64	1,53	

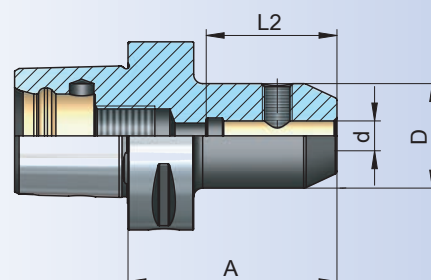
EPS  
(ISO 26623-1)

## Zubehör / Accessories / Accessoires / Yedekler



Spannschrauben  
Clamping screw  
Vis de serrage  
Sıkma civatası



11.05



## End mill holder

## Porte-fraises

## Veldon tutucu

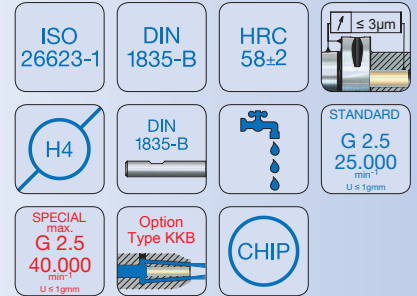

Bestell-Nr. Order Nr. Reference Sipariş Nr.	EPS	d	A	D	L2	Kg	Euro
EP6.04.06.55	EPS 63	6	55	25	36	0,85	
EP6.04.06.100	EPS 63	6	100	25	36	1,00	
EP6.04.08.55	EPS 63	8	55	28	40	0,88	
EP6.04.08.100	EPS 63	8	100	28	40	1,08	
EP6.04.10.60	EPS 63	10	60	35	44	0,99	
EP6.04.10.100	EPS 63	10	100	35	44	1,25	
EP6.04.12.60	EPS 63	12	60	42	51	1,09	
EP6.04.12.100	EPS 63	12	100	42	51	1,48	
EP6.04.14.60	EPS 63	14	60	44	51	1,11	
EP6.04.14.100	EPS 63	14	100	44	51	1,55	
EP6.04.16.65	EPS 63	16	65	48	54	1,24	
EP6.04.16.100	EPS 63	16	100	48	54	1,70	
EP6.04.18.65	EPS 63	18	65	50	54	1,27	
EP6.04.18.100	EPS 63	18	100	50	54	1,77	
EP6.04.20.65	EPS 63	20	65	52	56	1,29	
EP6.04.20.100	EPS 63	20	100	52	56	1,83	
EP6.04.25.80	EPS 63	25	80	63	64	1,82	
EP6.04.25.100	EPS 63	25	100	63	64	2,29	
EP6.04.32.90	EPS 63	32	90	72	68	2,35	
EP6.04.32.100	EPS 63	32	100	72	68	2,66	
EP6.04.40.100	EPS 63	40	100	80	78	2,85	

EP8.04.06.70	EPS 80	6	70	25	36	1,84	
EP8.04.08.70	EPS 80	8	70	28	40	1,88	
EP8.04.10.70	EPS 80	10	70	35	44	1,96	
EP8.04.12.70	EPS 80	12	70	42	51	2,07	
EP8.04.14.70	EPS 80	14	70	44	51	2,09	
EP8.04.16.70	EPS 80	16	70	48	54	2,16	
EP8.04.18.70	EPS 80	18	70	50	54	2,18	
EP8.04.20.70	EPS 80	20	70	52	56	2,19	
EP8.04.25.80	EPS 80	25	80	63	64	2,57	
EP8.04.32.80	EPS 80	32	80	72	68	2,78	
EP8.04.40.110	EPS 80	40	110	80	78	3,92	
EP8.04.50.120	EPS 80	50	120	98	88	5,30	

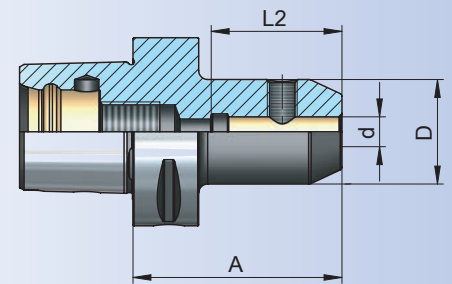

## Zubehör / Accessories / Accessoires / Yedekler



Spannschrauben  
Clamping screw  
Vis de serrage  
Sıkma civatası



11.05





End mill holder 2°

Porte-fraises 2°

Veldon tutucu 2°

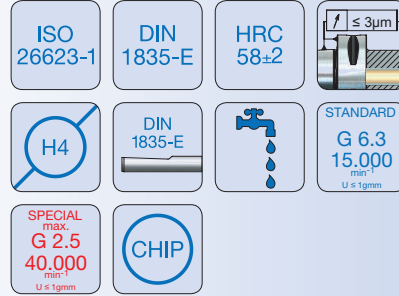

Bestell-Nr. Order Nr. Reference Sipariş Nr.	HSK	d	A	D	L2	Kg	Euro
EP3.05.06.70	EPS 32	6	70	25	36	0,30	
EP3.05.08.70	EPS 32	8	70	28	40	0,35	
EP3.05.10.70	EPS 32	10	70	35	44	0,47	
EP3.05.12.75	EPS 32	12	75	42	51	0,67	
EP4.05.06.70	EPS 40	6	70	25	36	0,42	
EP4.05.08.70	EPS 40	8	70	28	40	0,46	
EP4.05.10.70	EPS 40	10	70	35	44	0,57	
EP4.05.12.75	EPS 40	12	75	42	51	0,76	
EP4.05.14.75	EPS 40	14	75	44	51	0,79	
EP5.05.06.70	EPS 50	6	70	25	36	0,59	
EP5.05.08.70	EPS 50	8	70	28	40	0,64	
EP5.05.10.70	EPS 50	10	70	35	44	0,75	
EP5.05.12.75	EPS 50	12	75	42	51	0,93	
EP5.05.14.75	EPS 50	14	75	44	51	0,97	
EP5.05.16.80	EPS 50	16	80	48	54	1,14	
EP5.05.18.80	EPS 50	18	80	50	54	1,18	
EP5.05.20.85	EPS 50	20	85	52	56	1,30	
EP6.05.06.75	EPS 63	6	75	25	36	0,93	
EP6.05.08.75	EPS 63	8	75	28	40	0,98	
EP6.05.10.75	EPS 63	10	75	35	44	1,10	
EP6.05.12.80	EPS 63	12	80	42	51	1,30	
EP6.05.14.80	EPS 63	14	80	44	51	1,34	
EP6.05.16.80	EPS 63	16	80	48	54	1,44	
EP6.05.18.80	EPS 63	18	80	50	54	1,48	
EP6.05.20.85	EPS 63	20	85	52	56	1,60	
EP6.05.25.90	EPS 63	25	90	63	64	2,07	
EP6.05.32.95	EPS 63	32	95	72	68	2,54	

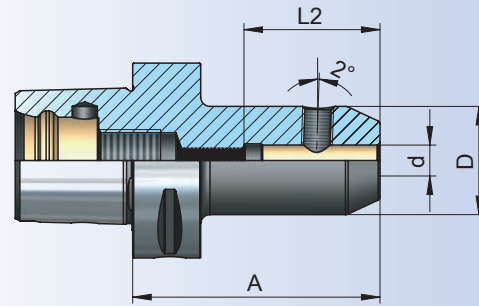
EPS  
(ISO 26623-1)

## Zubehör / Accessories / Accessoires / Yedekler

DIN 1835 B



10.38

Spannschrauben  
Clamping screw  
Vis de serrage  
Sıkma civatası

DIN 916



10.41 - 10.43

Einstellschraube  
Adjusting screw  
Vis de réglage  
Dayama civatası



## Fräseraufnahmen 2° Whistle-Notch

EPS

End mill holder 2°

Porte-fraises 2°

Veldon tutucu 2°

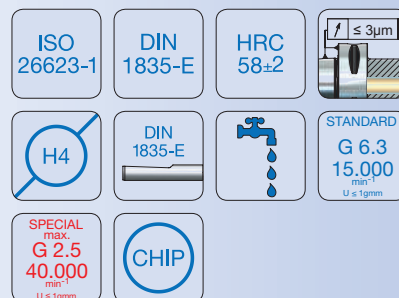

Bestell-Nr. Order Nr. Reference Sipariş Nr.	HSK	d	A	D	L2	Kg	Euro
--	-----	---	---	---	----	----	------

EP8.05.06.65	EPS 80	6	65	25	36	1,83	
EP8.05.08.65	EPS 80	8	65	28	40	1,87	
EP8.05.10.65	EPS 80	10	65	35	44	1,94	
EP8.05.12.70	EPS 80	12	70	42	51	2,07	
EP8.05.14.70	EPS 80	14	70	44	51	2,10	
EP8.05.16.75	EPS 80	16	75	48	54	2,23	
EP8.05.18.75	EPS 80	18	75	50	54	2,26	
EP8.05.20.80	EPS 80	20	80	52	56	2,35	
EP8.05.25.90	EPS 80	25	90	63	64	2,85	
EP8.05.32.95	EPS 80	32	95	72	68	3,27	

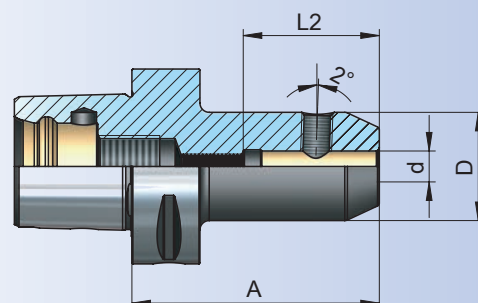

## Zubehör / Accessories / Accessoires / Yedekler



Spannschrauben  
Clamping screw  
Vis de serrage  
Sıkma civatası



Einstellschraube  
Adjusting screw  
Vis de réglage  
Dayama civatası

## Morsekegel-Aufnahmen mit Austreibblappen

EPS

Morse taper adaptor

Douilles intermédiaires pour outils à cône Morse

Mors adaptörü

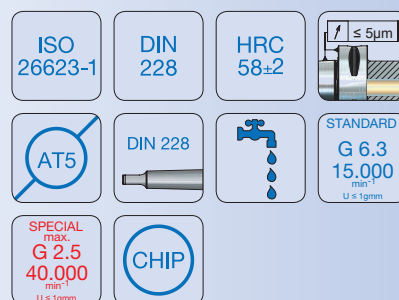

Bestell-Nr. Order Nr. Reference Sipariş Nr.	EPS	MK	A	D	Kg	Euro
--	-----	----	---	---	----	------

EP6.07.02.110	EPS 63	MK 2	110	32	1,15	
EP6.07.03.130	EPS 63	MK 3	130	40	1,48	
EP6.07.04.155	EPS 63	MK 4	155	48	1,95	

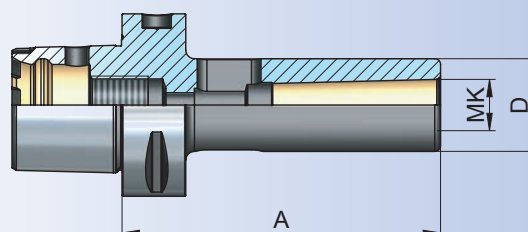



Combi shell mill holder

Porte-fraises à double usage pour fraises à entraînement par clavette ou tenon

Kombine malafa

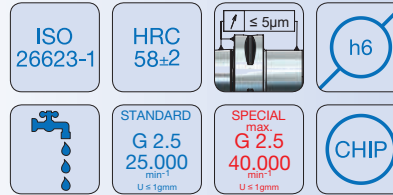

Bestell-Nr. Order Nr. Reference Sipariş Nr.	EPS	d	A	D	L3	L4	Kg	Euro
EP3.10.16.45	EPS 32	16	45	32	17	27	0,32	
EP4.10.16.45	EPS 40	16	45	32	17	27	0,43	
EP4.10.22.50	EPS 40	22	50	40	19	31	0,59	
EP5.10.16.45	EPS 50	16	45	32	17	27	0,6	
EP5.10.16.70	EPS 50	16	70	32	17	27	0,75	
EP5.10.22.45	EPS 50	22	45	40	19	31	0,72	
EP5.10.22.70	EPS 50	22	70	40	19	31	0,95	
EP5.10.27.55	EPS 50	27	55	48	21	33	1,01	
EP5.10.32.55	EPS 50	32	55	58	24	38	1,29	
EP6.10.16.50	EPS 63	16	50	32	17	27	0,95	
EP6.10.16.100	EPS 63	16	100	32	17	27	1,24	
EP6.10.22.55	EPS 63	22	55	40	19	31	1,12	
EP6.10.22.100	EPS 63	22	100	40	19	31	1,53	
EP6.10.27.55	EPS 63	27	55	48	21	33	1,31	
EP6.10.27.100	EPS 63	27	100	48	21	33	1,91	
EP6.10.32.55	EPS 63	32	55	58	24	38	1,59	
EP6.10.40.60	EPS 63	40	60	70	27	41	2,18	
EP8.10.16.60	EPS 80	16	60	32	17	27	1,93	
EP8.10.22.60	EPS 80	22	60	40	19	31	2,06	
EP8.10.27.65	EPS 80	27	65	48	21	33	2,30	
EP8.10.32.65	EPS 80	32	65	58	24	38	2,60	
EP8.10.40.70	EPS 80	40	70	70	27	41	3,21	

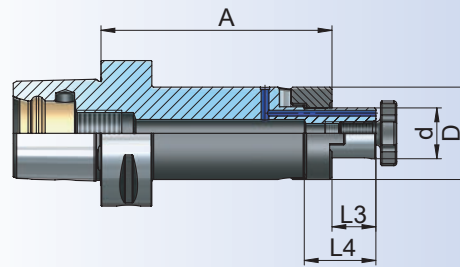

EPS  
(ISO 26623-1)

Zubehör / Accessories / Accessoires / Yedekler



Mitnehmerringe  
Clutch drive rings to  
Bague d'entraînement  
Tırnaklı pul



Fräseranzugsschrauben  
Draw in bolt  
Vis de serrage  
Alın sıkma civatası



Paßfeder  
Drive key  
Ressort de passage  
Kama



Spannschlüssel für  
Aufsteckdorne  
Wrench  
Clé de serrage  
Alın civatası sıkma anahtarı



## Quernut-Aufsteckdorne mit vergrößertem Bunddurchmesser

EPS

Shell mill holder for cutters with driving slot

Porte-fraises à surfacer avec diamètre de collerette élargi

Alın kamalı malafa

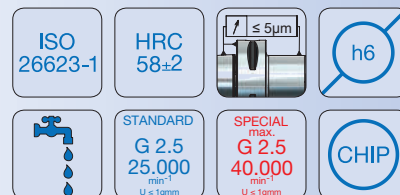

Bestell-Nr. Order Nr. Reference Sipariş Nr.	EPS	d	A	D	L3	Kg	Euro
EP3.11.16.30	EPS 32	16	30	38	17	0,27	
EP4.11.16.35	EPS 40	16	35	38	17	0,41	
EP4.11.22.40	EPS 40	22	40	48	19	0,59	
EP5.11.16.35	EPS 50	16	35	38	17	0,59	
EP5.11.16.70	EPS 50	16	70	38	17	0,88	
EP5.11.22.40	EPS 50	22	40	48	19	0,77	
EP5.11.22.70	EPS 50	22	70	48	19	1,17	
EP5.11.27.40	EPS 50	27	40	60	21	0,95	
EP6.11.16.35	EPS 63	16	35	38	17	0,90	
EP6.11.16.100	EPS 63	16	100	38	17	1,45	
EP6.11.22.40	EPS 63	22	40	48	19	1,07	
EP6.11.22.100	EPS 63	22	100	48	19	1,87	
EP6.11.27.40	EPS 63	27	40	60	21	1,27	
EP6.11.27.100	EPS 63	27	100	60	21	2,54	
EP6.11.32.40	EPS 63	32	40	78	24	4,60	
EP8.11.27.50	EPS 80	27	50	60	21	2,28	
EP8.11.27.100	EPS 80	27	100	60	21	3,34	
EP8.11.32.50	EPS 80	32	50	78	24	2,66	
EP8.11.32.100	EPS 80	32	100	78	24	4,48	
EP8.11.40.55	EPS 80	40	55	88	27	3,15	

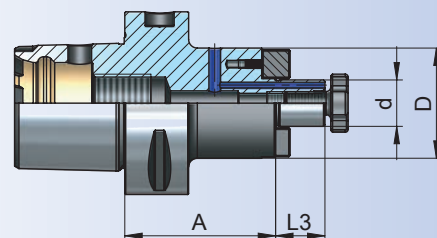

### Zubehör / Accessories / Accessoires / Yedekler



Fräseranzugsschrauben  
Drawn in bolt  
Vis de serrage  
Alın sıkma civatası



Mitnehmersteine  
Drive keys  
Entraîneur  
Kama



Spannschlüssel für Aufsteckdorne  
Wrench  
Clé de serrage  
Alın civatası sıkma anahtarı



## Milling Cutter Arbors for Screw-on type Milling Cutters

## Axes Coupeur Fraisage Pour Vis-Sur Type Coupeurs de Fraisage

## Vidalı tip frezeler için takım tutucular

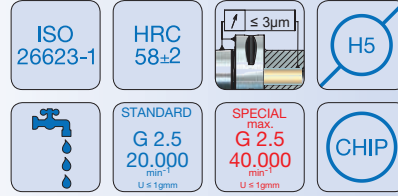

Bestell-Nr. Order Nr. Reference Sipariş Nr.	EPS	M	A	d	D	D1	Kg	Euro
EP3.12.08.30	EPS 32	M8	30	8,5	13	14,5	0,12	
EP3.12.10.30	EPS 32	M10	30	10,5	18	19,5	0,13	
EP3.12.12.35	EPS 32	M12	35	12,5	21	23,5	0,15	
EP3.12.16.40	EPS 32	M16	40	17	29	-	0,20	

EP4.12.08.30	EPS 40	M8	30	8,5	13	14,5	0,25	
EP4.12.10.35	EPS 40	M10	35	10,5	18	19,5	0,27	
EP4.12.12.40	EPS 40	M12	40	12,5	21	23,5	0,29	
EP4.12.16.45	EPS 40	M16	45	17	29	-	0,33	

EP5.12.08.50	EPS 50	M8	50	8,5	13	15	0,44	
EP5.12.08.75	EPS 50	M8	75	8,5	13	22,5	0,51	
EP5.12.10.50	EPS 50	M10	50	10,5	18	20	0,47	
EP5.12.10.75	EPS 50	M10	75	10,5	18	23	0,54	
EP5.12.12.50	EPS 50	M12	50	12,5	21	24	0,49	
EP5.12.12.75	EPS 50	M12	75	12,5	21	24	0,56	
EP5.12.16.50	EPS 50	M16	50	17	29	-	0,52	
EP5.12.16.75	EPS 50	M16	75	17	29	34	0,69	

EP6.12.08.50	EPS 63	M8	50	8,5	13	15	0,77	
EP6.12.08.75	EPS 63	M8	75	8,5	13	22,5	0,84	
EP6.12.10.50	EPS 63	M10	50	10,5	18	20	0,79	
EP6.12.10.75	EPS 63	M10	75	10,5	18	23	0,86	
EP6.12.12.50	EPS 63	M12	50	12,5	21	24	0,81	
EP6.12.12.75	EPS 63	M12	75	12,5	21	24	0,88	
EP6.12.16.50	EPS 63	M16	50	17	29	-	0,85	
EP6.12.16.75	EPS 63	M16	75	17	29	34	1,01	

EP8.12.08.85	EPS 80	M8	85	8,5	13	22,5	1,81	
EP8.12.10.85	EPS 80	M10	85	10,5	18	23	1,84	
EP8.12.12.85	EPS 80	M12	85	12,5	21	24	1,85	
EP8.12.16.85	EPS 80	M16	85	17	29	34	1,99	

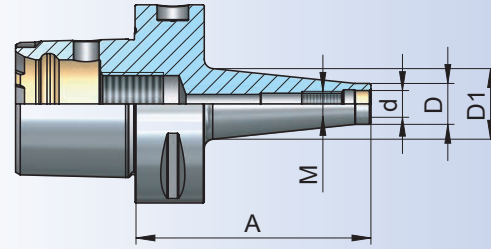

Empfohlene Anzugsmomente  
Recommended tightening torques  
Torques de serrage recommandés  
Önerilen sıkma torqu

M6	10 Nm
M8	25 Nm
M10	40 Nm
M12	60 Nm
M16	80 Nm

## Zubehör / Accessories / Accessoires / Yedekler



Verlängerungen für Einschraubfräser  
Extensions for milling cutter arbors  
Extension pour - sur - type  
coupeurs de fraisage  
Vidalı tip frezeler için ara adaptör



Reduzierungen für Einschraubfräser  
Reducing for milling cutter arbors  
Extension pour vis - sur - type  
coupeurs de fraisage  
Vidalı tip frezeler için ara adaptör



## Bohrerhalter für Wendepplattenbohrer E1

EPS

Boring holder for drill with indexable insert form E1

Porte foret pour foret à plaquettes réversible forme E1

Takma uçlu drill tutucu E1 Formu

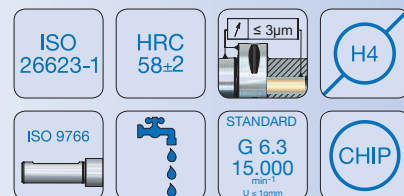

Bestell-Nr. Order Nr. Reference Sipariş Nr.	EPS	d	A	D	L2	Kg	Euro
EP3.51.16.56	EPS 32	16	56	36	52	0,35	
EP3.51.20.60	EPS 32	20	60	40	54	0,42	
EP4.51.16.56	EPS 40	16	56	36	52	0,45	
EP4.51.20.60	EPS 40	20	60	40	54	0,50	
EP4.51.25.77	EPS 40	25	77	45	59	0,71	
EP5.51.16.65	EPS 50	16	65	36	52	0,69	
EP5.51.20.60	EPS 50	20	60	40	54	0,69	
EP5.51.25.71	EPS 50	25	71	45	59	0,84	
EP5.51.32.75	EPS 50	32	75	52	63	0,93	
EP6.51.16.70	EPS 63	16	70	36	52	1,06	
EP6.51.20.70	EPS 63	20	70	40	54	1,12	
EP6.51.25.72	EPS 63	25	72	45	59	1,16	
EP6.51.32.75	EPS 63	32	75	52	63	1,24	
EP6.51.40.85	EPS 63	40	85	63	73	1,57	
EP8.51.16.80	EPS 80	16	80	36	52	2,07	
EP8.51.20.80	EPS 80	20	80	40	54	2,12	
EP8.51.25.85	EPS 80	25	85	45	59	2,15	
EP8.51.32.90	EPS 80	32	90	52	63	2,29	
EP8.51.40.95	EPS 80	40	95	63	73	2,93	

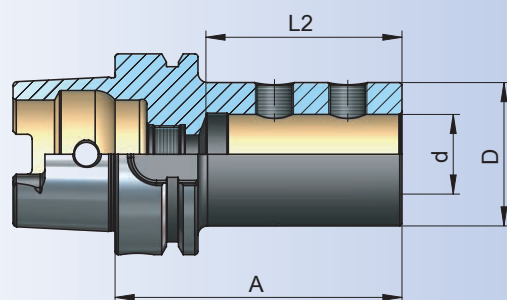

Zubehör / Accessories / Accessoires / Yedekler



## Bohrerhalter Form E2

Boring bar holder form E2

Porte-outil pour barre d'alésage forme E2

İç çap tornalama kater tutucu Form E2

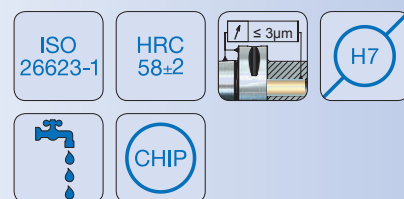

Bestell-Nr. Order Nr. Reference Sipariş Nr.	EPS	d	A	D	L2	Kg	Euro
EP5.52.25.100	EPS 50	25	100	63	80	2,15	
EP6.52.25.100	EPS 63	25	100	63	80	2,34	
EP6.52.32.105	EPS 63	32	105	67	90	2,44	
EP6.52.40.110	EPS 63	40	110	77	95	2,60	
EP8.52.25.100	EPS 80	25	100	63	80	3,15	
EP8.52.32.105	EPS 80	32	105	67	90	3,25	
EP8.52.40.110	EPS 80	40	110	77	95	3,70	

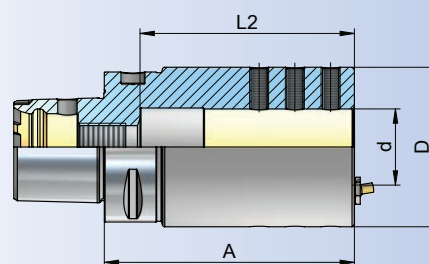

Zubehör / Accessories / Accessoires / Yedekler





## NC - Bohrfutter für Rechts - und Linkslauf

EPS



NC-Drill chucks for left and right rotation

Mandrin de perçage CNC pour rotation gauche-droite

NC tipi mandren malafası komple sağ ve sol dönüşlü

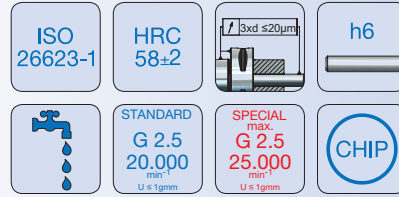

Bestell-Nr. Order Nr. Reference Sipariş Nr.	EPS	Spannbereich Capacity Capacité Kapasite	A	D	A1 Max.	Kg	Euro
EP3.15.13.105	EPS 32	1,0 - 13	105	50	113	1,31	
EP4.15.13.110	EPS 40	1,0 - 13	110	50	118	1,42	
EP5.15.13.110	EPS 50	1,0 - 13	110	50	118	1,51	
EP5.15.16.115	EPS 50	3,0 - 16	115	57	120	1,85	
EP6.15.13.110	EPS 63	1,0 - 13	110	50	118	1,87	
EP6.15.16.115	EPS 63	3,0 - 16	115	57	120	2,12	

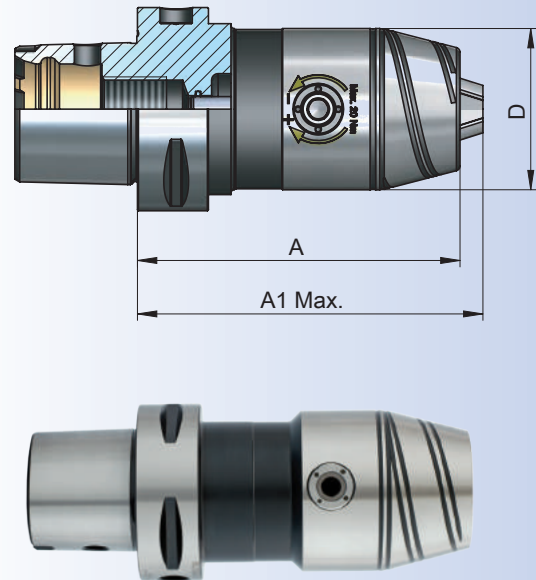

EPS  
(ISO 26623-1)

## Zubehör / Accessories / Accessoires / Yedekler



10.55-10.57

Ersatzteile  
Spare Parts  
Pièce de rechange  
Yedek parçalar



10.49

Spannschlüssel  
Wrench  
Clé de serrage  
Sıkma anahtarı



11.06



## Gewindeschneid - Schnellwechselfutter mit Längenausgleich auf Druck und Zug

EPS

Quick-change tapping chucks with length compensation

Appareil à tarauder avec compensation longitudinale

Kılavuz çekme başlığı giriş ve çıkış kompanzeli

ISO  
26623-1

HRC  
58±2



Bestell-Nr. Order Nr. Reference Sipariş Nr.	EPS	Spannbereich Capacity Capacité Kapasite	d	A	D	C	T	Kg	Euro
EP3.16.12.80	EPS 32	M2-M14	19	80	36,5	7	7	0,71	
EP4.16.12.80	EPS 40	M2-M14	19	80	36,5	7	7	0,65	
EP4.16.20.110	EPS 40	M5-M24	31	110	53,5	12	12	1,09	
EP5.16.12.80	EPS 50	M2-M14	19	80	36,5	7	7	0,83	
EP5.16.20.115	EPS 50	M5-M24	31	115	53,5	12	12	1,58	
EP6.16.12.90	EPS 63	M2-M14	19	90	36,5	7	7	1,35	
EP6.16.20.120	EPS 63	M5-M24	31	120	53,5	12	12	2,01	
EP6.16.36.170	EPS 63	M14-M36	48	170	78	17,5	17,5	4,56	
EP8.16.12.85	EPS 80	M2-M14	19	85	36,5	7	7	2,15	
EP8.16.20.110	EPS 80	M5-M24	31	110	53,5	12	12	1,94	
EP8.16.36.160	EPS 80	M14-M36	48	160	78	17,5	17,5	4,38	

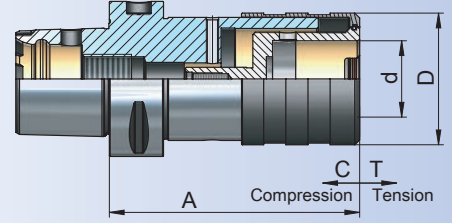

Ausführung : Mit Kugelführungsbuchse

Version : With ball retainer

Version : Comprenant douille de glissière à bille

Teknik özelliği : Bilya Kafesli

## Gewindeschneid - Schnellwechselfutter ohne Längenausgleich auf Druck und Zug

EPS

Quick-change tapping chucks without length compensation

Appareil à tarauder sans compensation longitudinale

Kılavuz çekme başlığı sabit

ISO  
26623-1

HRC  
58±2



Bestell-Nr. Order Nr. Reference Sipariş Nr.	EPS	Spannbereich Capacity Capacité Kapasite	d	A	D	Kg	Euro
EP4.16.12.1.60	EPS 40	M2-M14	19	60	38	0,47	
EP5.16.12.1.60	EPS 50	M2-M14	19	60	38	0,73	
EP5.16.20.1.95	EPS 50	M5-M24	31	95	52	1,17	
EP6.16.20.1.105	EPS 63	M5-M24	31	105	52	1,62	
EP6.16.36.1.120	EPS 63	M14-M36	48	120	78	2,91	

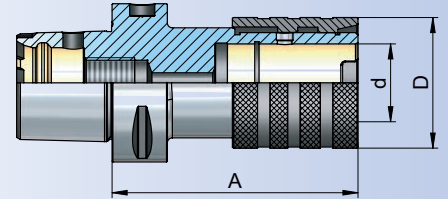

## Zubehör / Accessories / Accessoires / Yedekler



Schnellwechseleinsätze  
Tapping collets  
Douilles de taraudage  
Kılavuz tutucu



Boring bar blanks for the production of special tools

Barre d'alésage pour la fabrication d'outils spéciaux

Özel takım yapma amaçlı yarı mamul

ISO  
26623-1HRC  
52±2

CHIP

Bestell-Nr. Order Nr. Reference Sipariş Nr.	EPS	D	A	Kg	Euro
EP3.17.32.125	EPS 32	32	125	0,80	
EP4.17.40.165	EPS 40	40	165	1,67	
EP4.17.70.100	EPS 40	70	100	2,61	
EP5.17.50.175	EPS 50	50	175	2,80	
EP5.17.75.70	EPS 50	75	70	2,11	
EP6.17.63.195	EPS 63	63	195	4,96	
EP6.17.63.310	EPS 63	63	310	7,75	
EP6.17.80.250	EPS 63	80	250	9,66	

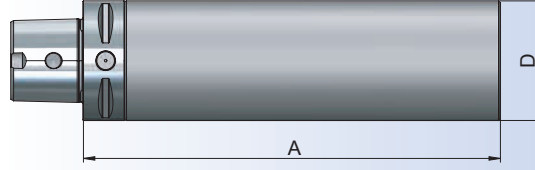
EPS  
(ISO 26623-1)

Ausführung : Steilkegel und Bund gehärtet ( $52\pm 2$  HRC) und geschliffen,  
Schaft weich zur weiteren Bearbeitung.

Version : Cone and flange hardened ( $52\pm 2$  HRC) and grinded.  
Soft body for later processing.

Version : Cône et collerette durcir ( $52\pm 2$  HRC) et rectifiés.  
Corps doux pour un usinage ultérieur.

Teknik özelliği: Konik ve Flanş kısmı sertleştirilmiş ( $52\pm 2$  HRC) ve taşlanmıştır.  
Bara kısmı işlenebilir yumuşaklıktadır.



## Kontrolldorne

EPS

### Test arbors

### Mandrins de contrôle

### Fener mili kontrol mastarı

ISO  
26623-1

HRC  
58±2

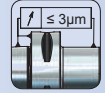

Bestell-Nr. Order Nr. Reference Sipariş Nr.	EPS	D	A	Kg	Euro
EP3.18.25.150	EPS 32	25	150	0,62	
EP4.18.25.150	EPS 40	25	150	0,74	
EP5.18.32.200	EPS 50	32	200	1,54	
EP6.18.40.300	EPS 63	40	300	3,47	
EP8.18.40.300	EPS 80	40	300	4,36	

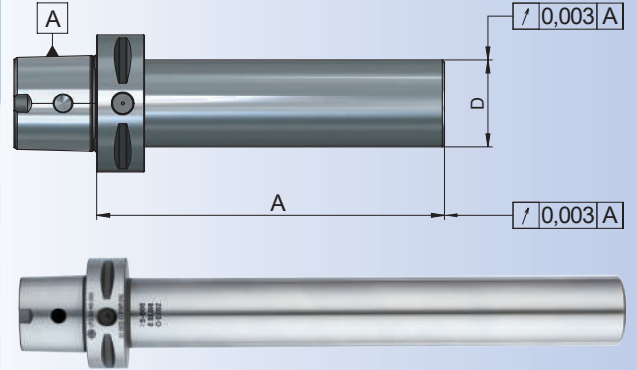

- Verwendung : Zur Abnahme von Werkzeugmaschinen gemäß ISO-Empfehlung R230
- Application : For acceptance tests of machine tools in accordance with ISO-recommendation R230
- Application : Pour la recette technique des machines conforme recommandation ISO R230
- Açıklama : Tezgahları devreye alırken ISO Normu R230 sisteminde uygunluğunu kontrol etmek için

## Einrichtehalter

EPS

### Setting-holder

### Porte-outil de réglage

### Fener mili pozisyon kontrol mastarı

ISO  
26623-1

HRC  
58±2



Bestell-Nr. Order Nr. Reference Sipariş Nr.	EPS	D	A	H	S	Kg	Euro
EP6.19.90.55	EPS 63	90	55	8	5	2,98	

- Verwendung : Zur Abnahme von Werkzeugmaschinen gemäß ISO-Empfehlung R230
- Application : For acceptance tests of machine tools in accordance with ISO-recommendation R230
- Application : Pour la recette technique des machines conforme recommandation ISO R230
- Açıklama : Tezgahları devreye alırken ISO Normu R230 sisteminde uygunluğunu kontrol etmek için

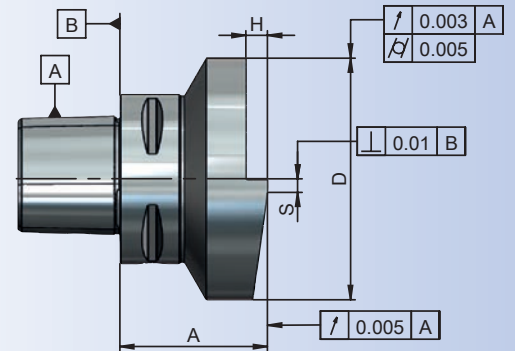



Shrink chuck for mounting of solid carbide cutters

Mandrin de frettage pour le serrage des queue d'outils carbure

Isıtmalı takım tutucular şaftı karbür olan takımlar için

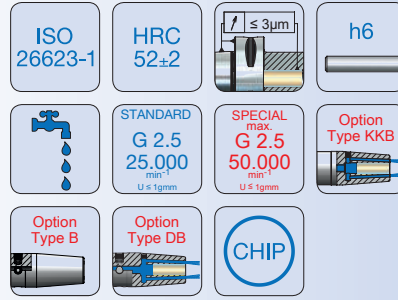

Bestell-Nr. Order Nr. Reference Sipariş Nr.	EPS	d	A	D	D1	L2	Kg	Euro
EP3.25.06.65	EPS 32	6	65	21	27	36	0,29	
EP3.25.08.65	EPS 32	8	65	21	27	36	0,29	
EP3.25.10.70	EPS 32	10	70	24	32	42	0,36	
EP3.25.12.75	EPS 32	12	75	24	32	47	0,37	

EP4.25.06.75	EPS 40	6	75	21	27	36	0,45	
EP4.25.08.75	EPS 40	8	75	21	27	36	0,44	
EP4.25.10.75	EPS 40	10	75	24	32	42	0,49	
EP4.25.12.75	EPS 40	12	75	24	32	47	0,48	
EP4.25.14.80	EPS 40	14	80	27	34	47	0,55	
EP4.25.16.80	EPS 40	16	80	27	34	50	0,53	

EP5.25.06.75	EPS 50	6	75	21	27	36	0,62	
EP5.25.08.75	EPS 50	8	75	21	27	36	0,61	
EP5.25.10.75	EPS 50	10	75	24	32	42	0,67	
EP5.25.12.75	EPS 50	12	75	24	32	47	0,65	
EP5.25.14.80	EPS 50	14	80	27	34	47	0,73	
EP5.25.16.80	EPS 50	16	80	27	34	50	0,71	
EP5.25.18.80	EPS 50	18	80	33	42	50	0,84	
EP5.25.20.85	EPS 50	20	85	33	42	52	0,88	
EP5.25.25.90	EPS 50	25	90	44	53	58	1,24	
EP5.25.32.90	EPS 50	32	90	44	53	62	1,08	

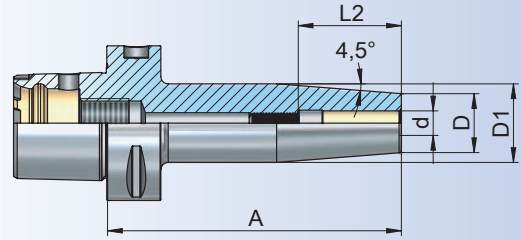

EPS  
(ISO 26623-1)

Zubehör / Accessories / Accessoires / Yedekler

DIN 916	Einstellschraube Adjusting screw Vis de réglage Dayama civatası		11.08
10.41-10.43			



Shrink chuck for mounting of solid carbide cutters

Mandrin de frettage pour le serrage des queue d'outils carbure

Isitmalı takım tutucular şaftı karbür olan takımlar için

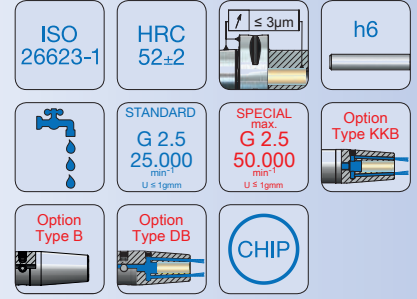

Bestell-Nr. Order Nr. Reference Sipariş Nr.	EPS	d	A	D	D1	L2	Kg	Euro
EP6.25.03.80	EPS 63	3	80	10	16	14	0,81	
EP6.25.04.80	EPS 63	4	80	12	20	17	0,84	
EP6.25.05.80	EPS 63	5	80	12	21	20	0,84	
EP6.25.06.80	EPS 63	6	80	21	27	36	0,96	
EP6.25.06.120	EPS 63	6	120	21	27	36	1,12	
EP6.25.06.160	EPS 63	6	160	21	27	36	1,29	
EP6.25.08.80	EPS 63	8	80	21	27	36	0,95	
EP6.25.08.120	EPS 63	8	120	21	27	36	1,12	
EP6.25.08.160	EPS 63	8	160	21	27	36	1,28	
EP6.25.10.80	EPS 63	10	80	24	32	42	1,01	
EP6.25.10.120	EPS 63	10	120	24	32	42	1,25	
EP6.25.10.160	EPS 63	10	160	24	32	42	1,48	
EP6.25.12.80	EPS 63	12	80	24	32	47	1,00	
EP6.25.12.120	EPS 63	12	120	24	32	47	1,21	
EP6.25.12.160	EPS 63	12	160	24	32	47	1,43	
EP6.25.14.85	EPS 63	14	85	27	34	47	1,07	
EP6.25.14.120	EPS 63	14	120	27	34	47	1,29	
EP6.25.14.160	EPS 63	14	160	27	34	47	1,54	
EP6.25.16.85	EPS 63	16	85	27	34	50	1,05	
EP6.25.16.120	EPS 63	16	120	27	34	50	1,27	
EP6.25.16.160	EPS 63	16	160	27	34	50	1,52	
EP6.25.18.85	EPS 63	18	85	33	42	50	1,21	
EP6.25.18.120	EPS 63	18	120	33	42	50	1,55	
EP6.25.18.160	EPS 63	18	160	33	42	50	1,95	
EP6.25.20.85	EPS 63	20	85	33	42	52	1,18	
EP6.25.20.120	EPS 63	20	120	33	42	52	1,53	
EP6.25.20.160	EPS 63	20	160	33	42	52	1,93	
EP6.25.25.90	EPS 63	25	90	44	53	58	1,54	
EP6.25.25.120	EPS 63	25	120	44	53	58	2,03	
EP6.25.25.160	EPS 63	25	160	44	53	58	2,68	
EP6.25.32.95	EPS 63	32	95	44	53	62	1,46	
EP6.25.32.120	EPS 63	32	120	44	53	62	1,87	
EP6.25.32.160	EPS 63	32	160	44	53	62	2,52	

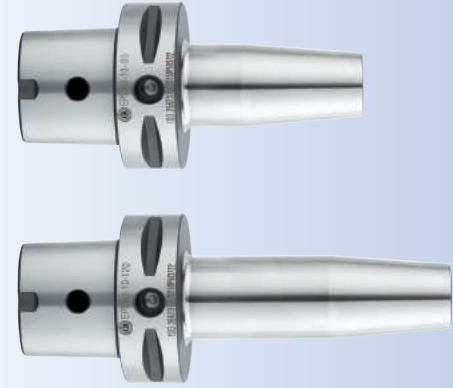
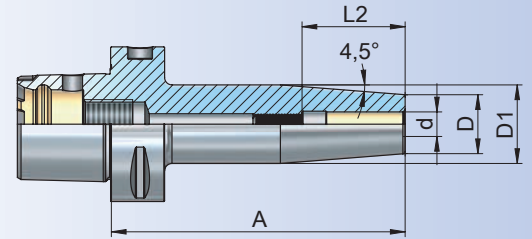

## Zubehör / Accessories / Accessoires / Yedekler

DIN 916



10.41-10.43

Einstellschraube  
Adjusting screw  
Vis de réglage  
Dayama civatası



11.08





Shrink chuck for mounting of solid carbide cutters

Mandrin de frettage pour le serrage des queue d'outils carbure

Isıtmalı takım tutucular şaftı karbür olan takımlar için

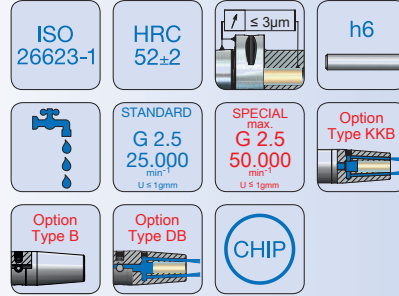

Bestell-Nr. Order Nr. Reference Sipariş Nr.	EPS	d	A	D	D1	L2	Kg	Euro
EP8.25.06.85	EPS 80	6	85	21	27	36	1,92	
EP8.25.08.85	EPS 80	8	85	21	27	36	1,91	
EP8.25.10.85	EPS 80	10	85	24	32	42	1,96	
EP8.25.12.85	EPS 80	12	85	24	32	47	1,94	
EP8.25.14.85	EPS 80	14	85	27	34	47	1,99	
EP8.25.16.90	EPS 80	16	90	27	34	50	2,00	
EP8.25.18.90	EPS 80	18	90	33	42	50	2,14	
EP8.25.20.90	EPS 80	20	90	33	42	52	2,11	
EP8.25.25.90	EPS 80	25	90	44	53	58	2,37	
EP8.25.32.90	EPS 80	32	90	44	53	62	2,21	

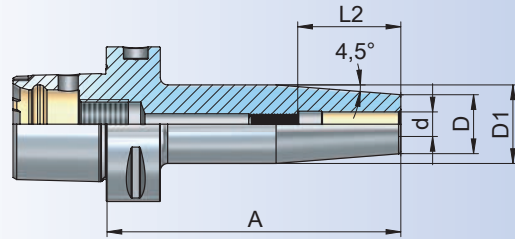

EPS  
(ISO 26623-1)

Zubehör / Accessories / Accessoires / Yedekler

DIN 916



Einsteilschraube  
Adjusting screw  
Vis de réglage  
Dayama civatası

10.41-10.43



11.08



## Hydraulic expansions chuck

## Mandrins expansibles hydrauliques

## Hidrolik takım tutucular

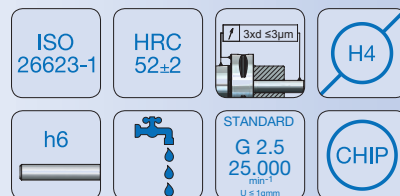

Bestell-Nr. Order Nr. Reference Sipariş Nr.	EPS	d	A	D	D1	L1	L2	Kg	Euro
EP3.65.12.80	EPS 32	12	80	50	32	40	46	0,60	
EP4.65.06.80	EPS 40	6	80	50	26	40	37	0,62	
EP4.65.08.80	EPS 40	8	80	50	28	40	37	0,65	
EP4.65.10.85	EPS 40	10	85	50	30	40	41	0,74	
EP4.65.12.85	EPS 40	12	85	50	32	40	46	0,83	
EP5.65.06.65	EPS 50	6	65	50	26	30	37	0,68	
EP5.65.08.65	EPS 50	8	65	50	28	30	37	0,69	
EP5.65.10.75	EPS 50	10	75	50	30	40	41	0,77	
EP5.65.12.80	EPS 50	12	80	50	32	40	46	0,84	
EP5.65.14.80	EPS 50	14	80	50	34	40	46	0,88	
EP5.65.16.85	EPS 50	16	85	50	38	46	49	0,93	
EP5.65.18.85	EPS 50	18	85	50	40	46	49	0,96	
EP5.65.20.85	EPS 50	20	85	50	42	46	51	0,97	
EP5.65.25.95	EPS 50	25	95	55	49,5	-	57	1,47	
EP6.65.06.65	EPS 63	6	65	50	26	25	37	1,04	
EP6.65.08.65	EPS 63	8	65	50	28	25	37	1,08	
EP6.65.10.75	EPS 63	10	75	50	30	35	41	1,12	
EP6.65.12.80	EPS 63	12	80	50	32	40	46	1,15	
EP6.65.14.80	EPS 63	14	80	50	34	40	46	1,22	
EP6.65.16.85	EPS 63	16	85	50	38	46	49	1,26	
EP6.65.18.85	EPS 63	18	85	50	40	46	49	1,32	
EP6.65.20.85	EPS 63	20	85	50	42	46	51	1,29	
EP6.65.25.95	EPS 63	25	95	55	49,5	-	57	1,83	
EP6.65.32.100	EPS 63	32	100	63	56	-	61	2,13	
EP8.65.20.95	EPS 80	20	95	50	42	46	51	2,28	
EP8.65.32.105	EPS 80	32	105	63	56	-	61	3,02	

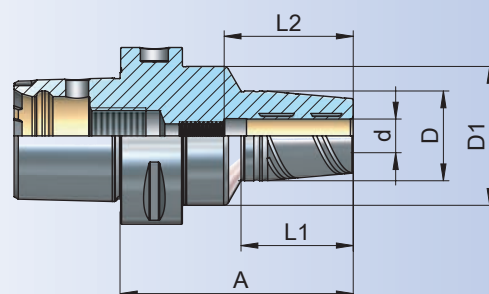

## Zubehör / Accessories / Accessoires / Yedekler



Reduzierungen  
Reducing arbor  
Douille de réduction  
Pens



DIN 916  
Einstellschraube  
Adjusting screw  
Vis de réglage  
Dayama civatası



Spannschlüssel  
Wrench  
Clé de serrage  
Sıkma anahtarı



Büchsenzieher für Reduzierungen  
Sleeve remover for reducing arbor  
Clé étirage pour douilles  
Hidrolik Takım Pensi Çıkarma Anahtarı



11.10

## Werkzeughalter Radial

EPS



Toolholder radial

Porte outil radial

Radyal kater tutucu

ISO  
26623-1

CHIP

Bestell-Nr. Order Nr. Référence Sipariş Nr.	EPS	D <sub>5M</sub>	h <sub>23</sub>	A	D <sub>1</sub>	b <sub>22</sub>	h <sub>21</sub>	l <sub>1</sub>	Kg	Euro
EP5.41.20.58	EPS 50	50	20	58	90	38	25,1	40	2,11	
EP6.41.20.60	EPS 63	63	20	60	90	38	31,6	42	2,01	
EP6.41.25.71	EPS 63	63	25	71	110	45	31,6	49	3,18	
EP6.41.32.71	EPS 63	63	32	71	130	50	32	46	3,40	
EP8.41.32.85	EPS 80	80	32	85	142	55	40,5	60	5,72	

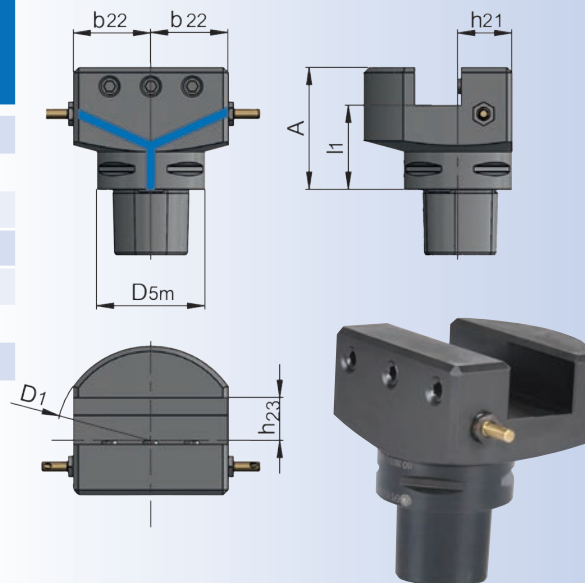

EPS  
(ISO 26623-1)

## Werkzeughalter Axial

Toolholder axial

Porte outil axial

Eksenel kater tutucu

ISO  
26623-1

CHIP

Bestell-Nr. Order Nr. Référence Sipariş Nr.	EPS	h <sub>23</sub>	A	D <sub>1</sub>	D <sub>5M</sub>	b <sub>21</sub>	b <sub>22</sub>	h <sub>21</sub>	h <sub>22</sub>	f	l <sub>22</sub>	l <sub>23</sub>	l <sub>24</sub>	Kg	Euro
EP5.42.20.98.R	EPS 50	20	98	90	50	29	30	41	33	12	88	20	26	2,17	
EP5.42.20.98.L	EPS 50	20	98	90	50	29	30	41	33	12	88	20	26	2,18	
EP6.42.20.100.R	EPS 63	20	100	90	63	29	30	41	33	12	90	22	25	2,51	
EP6.42.20.100.L	EPS 63	20	100	90	63	29	30	41	33	12	90	22	25	2,51	
EP6.42.25.130.R	EPS 63	25	130	100	63	32	38	50	33	16	120	22	28	3,63	
EP6.42.25.130.L	EPS 63	25	130	100	63	32	38	50	33	16	120	22	28	3,63	
EP8.42.32.140.R	EPS 80	32	140	110	80	40	40	55	30	15	130	30	35	5,64	
EP8.42.32.140.L	EPS 80	32	140	110	80	40	40	55	30	15	130	30	35	5,64	

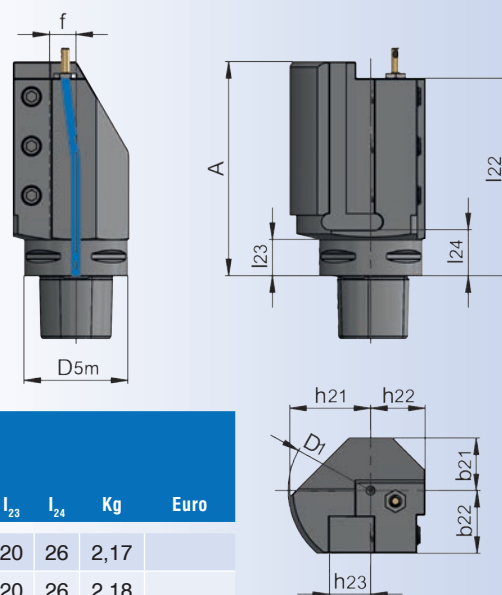



## Triplex Werkzeughalter Axial

EPS

Triplex toolholder axial

Triplex porte outil axial

Üçlü aksel kater tutucu

ISO  
26623-1

CHIP

Bestell-Nr. Order Nr. Référence Sipariş Nr.	EPS	$h_{23}$	A	$D_1$	$D_{5M}$	f	$I_{23}$	$I_{24}$	Kg	Euro
EP5.43.20.123.R	EPS 50	20	123	90	50	18	20	26	3,71	
EP5.43.20.123.L	EPS 50	20	123	90	50	18	20	26	3,71	
EP6.43.20.125.R	EPS 63	20	125	90	63	18	22	28	3,97	
EP6.43.20.125.L	EPS 63	20	125	90	63	18	22	28	3,97	
EP8.43.32.150.R	EPS 80	32	150	120	80	20	30	36	7,50	
EP8.43.32.150.L	EPS 80	32	150	120	80	20	30	36	7,50	

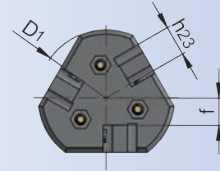
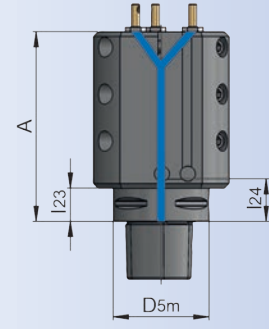

## Duplex Werkzeughalter Axial

EPS

Duplex toolholder axial

Duplex porte outil axial

İkili aksel kater tutucu

ISO  
26623-1

CHIP

Bestell-Nr. Order Nr. Référence Sipariş Nr.	EPS	$h_{23}$	A	$D_1$	$D_{5M}$	$b_{21}$	f	$I_{23}$	Kg	Euro
EP6.44.32.115	EPS 63	32	115	140	63	58	33	22	7,55	

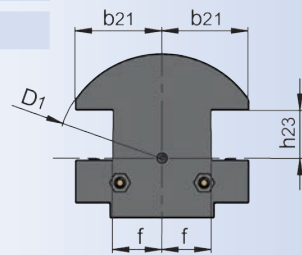
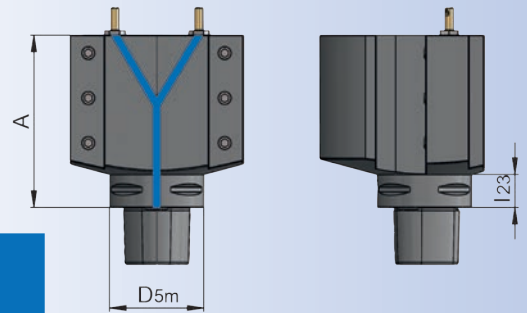



Toolholder 45°

Porte-outil 45°

Kater tutucu 45°

ISO  
26623-1

CHIP

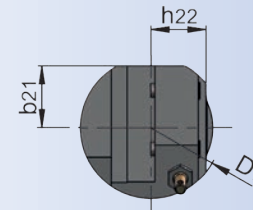
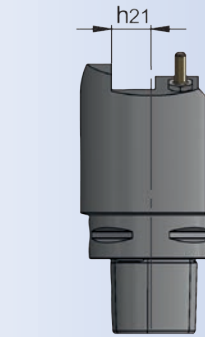
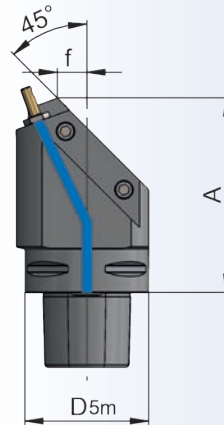

Bestell-Nr. Order Nr. Référence Sipariş Nr.	EPS	$h_{21}$	A	$D_1$	$D_{5m}$	$b_{21}$	$h_{22}$	f	Kg	Euro
EP5.45.20.97.R	EPS 50	20	97	72	50	30,6	26	15	1,73	
EP5.45.20.97.L	EPS 50	20	97	72	50	30,6	26	15	1,73	
EP6.45.20.99.R	EPS 63	20	99	72	63	31,5	28	15	2,27	
EP6.45.20.99.L	EPS 63	20	99	72	63	31,5	28	15	2,27	
EP8.45.32.135.R	EPS 80	32	135	140	80	45	40	17	6,69	
EP8.45.32.135.L	EPS 80	32	135	140	80	45	40	17	6,69	